

# CANTER 516

## DUONIC AMT OR MANUAL



**GVM:**  
4,983kg



**Power/Torque:**  
110kW / 370Nm



**Wheelbase:**  
2,800mm (C) / 3,400mm (E)

- 30,000km service intervals
- Disc brakes
- Car licence
- Independent front suspension

# SPECIFICATIONS - CANTER 516

## MODEL

4x2 516	WIDE CAB	6 SP.	AMT	FEB21CR3SFAC
4x2 516	WIDE CAB	5 SP.	MAN	FEB21CR4SFAC
4x2 516	WIDE CAB	6 SP.	AMT	FEB21ER3SFAC
4x2 516	WIDE CAB	5 SP.	MAN	FEB21ER4SFAC

## WHEELBASE (mm)

2,800 (C)
2,800 (C)
3,400 (E)
3,400 (E)

## GVM (kg)

4,983
4,983
4,983
4,983

## GCM (kg)

8,483
8,483
8,483
8,483

## ENGINE

Engine Version	FUSO 4P10-T4 Euro 5 Diesel
Configuration	4 Cyl. In-line DOHC, 4-Valve
Type	Variable Geometry Turbo Charged Air to Air Intercooled
Displacement	3 litre (2998cc)
Power (DIN)	110kW @ 2840~3500rpm
Torque (DIN)	370Nm @ 1350~2840rpm
Maximum Engine Speed	4100rpm
Compression Ratio	17.5:1
Cooling System / Oil Cooler	Water cooled with Viscous fan, 13.7L capacity. Engine oil cooler
Air Cleaner	Paper Element Type with Restrictor Indicator. Vertical Intake Mounted on Clean Air Side (RH)
Cold Start Preheat	Standard
Emission Control	Diesel Particulate Filter (DPF) Exhaust Dash Display DPF Status 0~9 (Empty~Full) Parked Regeneration possible from 7~9
Emission Level	EURO 5 (ADR 80/03) and EEV rated (Enhanced Environmentally-Friendly Vehicle)

## 4P10-T4

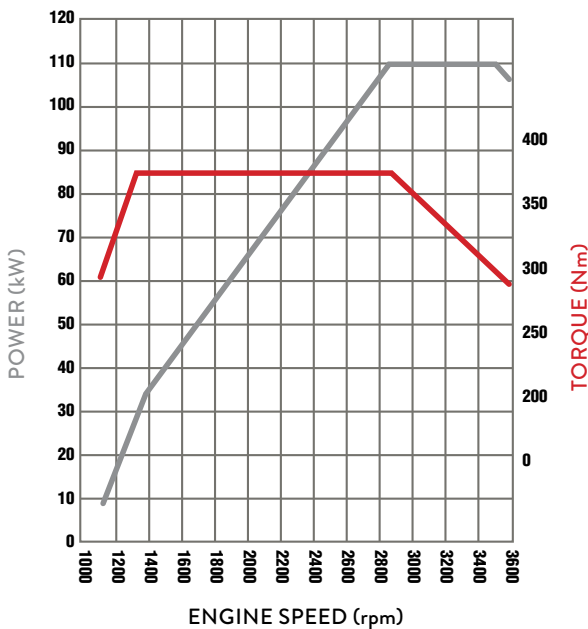

## FUEL

Injection System	Bosch Common Rail Direct Injection Bosch Piezo Technology Injectors
Tank Type	Rectangular Steel Tank with Locking Cap
Fuel Capacity (L)	100
Filtration	Filter with Water Separator and Indicator Sensor

## ELECTRICAL

Voltage	12V Negative Earth
Alternator Capacity	12V-110 amp

## ELECTRICAL (continued)

Battery Specification	Heavy Duty 115D31L x 2
Headlamp Type	Halogen 2 x 55W/60W
Fog lamp in bumper	Standard

## CLUTCH

	DUONIC AMT	Manual
Clutch Model	Duonic Automated Manual (no clutch pedal)	FUSO C4W30
Type	Dual Clutch (Wet Multi-plate)	Single Dry Plate, Direct Hydraulic Type, 300mm

## TRANSMISSION

	DUONIC AMT	Manual
Version	FUSO Duonic M038S6	FUSO M038S5
Type/Speeds	6 Speed Automated Manual with Auto and Manual Modes	5 Speed with In-Dash Gearshift Lever
Features	Virtually Instant Gear Changes; In-Dash Gear Lever with Park Brake Position; ECO Mode to Minimise Fuel Usage	Synchromesh 2nd-5th
Ratios	1st: 5.397 2nd: 3.788 3rd: 2.310 4th: 1.474 5th: 1.000 6th: 0.701 Rev. 5.397	1st: 5.494 2nd: 3.193 3rd: 1.689 4th: 1.000 5th: 0.723 Rev. 4.494
PTO Opening	LH Side.	LH Side

## FRONT AXLE

Axle	FUSO F200T Independent Front Suspension Type
Design Capacity (kg)	2,300
Max Operating Capacity (kg)	2,180

## FRONT SUSPENSION

Type	Double Wishbone Independent Front Suspension with Coil Springs and Shock Absorbers
------	--

## REAR AXLE

Axle	FUSO D03 Full Floating Banjo Type
Ratio	4.444:1
Design Capacity (kg)	3,800
Max Operating Capacity (kg)	3,800

## REAR SUSPENSION

Type	Steel Suspension
Details	Taper Leaf Spring with Stabiliser Bar and Double Acting Shock Absorbers
Size Main Leaves (mm)	1,100 x 70

## STEERING

Power Assisted	Tilt/Telescopic Adjustable Steering Wheel
----------------	---

# SPECIFICATIONS - CANTER 516

## BRAKES

Type	Hydraulic Dual Circuit with Front and Rear Single calipers Discs
Size Front / Rear (mm)	276 x 28
Features	ABS plus EBD (Electronic Brake Distribution) Exhaust Brake Brake Priority System
Park Brake	Transmission Mounted

## WHEELS AND TYRES

Wheel Type	7 x Single Piece Disc Rims (Including Spare)
Wheel Size	16.0 x 5.5K-115
Wheel Stud Pattern	5 Stud 208 PCD
Tyre Size All	185 / 85R16
Spare Tyre Carrier	Provided

## CHASSIS

Type	Reinforced Tapered Channel
Size (mm)	188 x 60 x 4
Width (mm)	750

Refer to the bodybuilders guidelines on the Fuso website ([www.fuso.co.nz](http://www.fuso.co.nz)) before mounting a body or modifying the chassis

## INSTRUMENTS

Gauges	Speedometer with Odometer Tachometer; Fuel Level Water Temperature
Colour Information Display	Fuel Consumption; DPF Bar Chart from 1-9 Water Temperature Maintenance Reminder System Tripmeters

## STANDARD FEATURES

Airbag(s)	Drivers Air Bag and Seat Belt Pre-Tensioner
Hill Start System	Adjustable Engagement on manual transmissions
Speed Limiter	Activated and adjustable by Fuso dealer
Cab Cooling and Heating	Air Conditioner / Heater / Demister
Accessory Power	12V Accessory Power Outlet / Cigar Lighter
Driving	AM/FM CD + USB + AUX + Bluetooth Hands Free Keyless Central Locking Electric Windows LED Map Lamp and Fluorescent Cabin Lamp Cup Holders (2)
Storage	Dual Overhead Storage Pockets In-Dash Centre Document Storage Door Storage Pockets Lockable Glove Box Coat Hooks
Cab: External	Front End-Outline Marker Lamps Front Step Lights
Chassis	Reverse Warning Buzzer

## CAB FEATURES

Type	All Steel Forward Control Manual Tilt
Cab Structure	ECE-R29 European Cab Strength Approved with Door Side Impact Beams
Mounting	Hydroelastic 4 Point
Colour	Natural White (W31)
Windscreen Wipers	2 Speed + Intermittent Cycle with Integrated Washer Nozzles
Rear Vision Mirrors	1 x Internal 2 x External Convex Heated
Interior	Fully Trimmed cab with vinyl floor covering
Seating Capacity	3
Seat Belts	Driver - Height adjustable ELR 3 Point with tension reducer Outside Passenger - ELR 3 point Centre Passenger - Lap belt
Seat (driver)	Heavy Duty Suspended with LH Arm Rest, Adjustable Lumbar Support and Weight Adjustment. Cloth Trim
Seats (passenger)	Flat Folding, 2 Passenger Bench with headrest in outside position

## SERVICE INTERVALS

Please contact your nearest Fuso dealer for details

## WARRANTY

36 months or 100,000km (whichever occurs sooner)  
Subject to terms and conditions in the Fuso Warranty Booklet

## PERFORMANCE

	DUONIC AMT	Manual
Turning Circle (kerb to kerb - metres)	C = 9.6 E = 11.0	C = 9.6 E = 11.0
Road Speed (km/h) at Max Engine Speed	136	136
Est Engine RPM at 90km/hr (top gear)	2110	2180
Gradeability at Rated GVM (theoretical)*	40%	41%
Notes	*This is theoretical performance only. Actual performance may vary under different conditions	

## KERB WEIGHTS AND MAX AXLE LOADS (kg)

Model		Vehicle Ratings**		Max Axle Loadings**		Kerb Weights*		
		GVM	GCM	Front	Rear	Front	Rear	Total
4x2 516 Wide Cab 6 Sp. AMT	FEB21CR3SFAC	4,983	8,483	2,180	3,800	1,480	585	2,065
4x2 516 Wide Cab 5 Sp. MAN	FEB21CR4SFAC	4,983	8,483	2,180	3,800	1,470	575	2,045
4x2 516 Wide Cab 6 Sp. AMT	FEB21ER3SFAC	4,983	8,483	2,180	3,800	1,490	600	2,090
4x2 516 Wide Cab 5 Sp. MAN	FEB21ER4SFAC	4,983	8,483	2,180	3,800	1,475	595	2,070

\* Weights (est.) includes 10L fuel and spare wheel and are subject to 2.5% variation (+/-)

\*\* Vehicle ratings and max axle loadings may be limited by local regulations.

# SPECIFICATIONS - CANTER 516

## DIMENSIONS (mm)

	C Wheelbase	E Wheelbase
Wheelbase	2,800	3,400
Length Overall	5,135	5,935
Height Overall	2,165	2,165
Width Overall	1,955	1,955
Width Rear Axle	1,925	1,925

	C Wheelbase	E Wheelbase
Width Front Track	1,655	1,655
Width Rear Track	1,495	1,495
Width Frame	750	750
Height Frame at Rear Axle	732	732

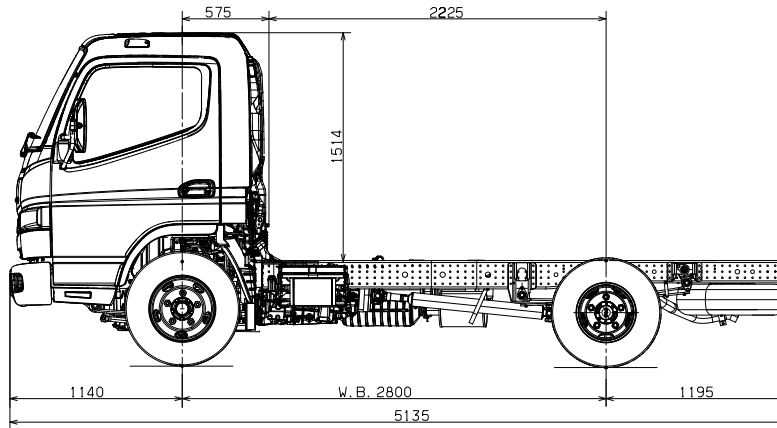

**CANTER 516 – 'C' WHEELBASE**

1000  
UNIT: mm 20mm = 1m

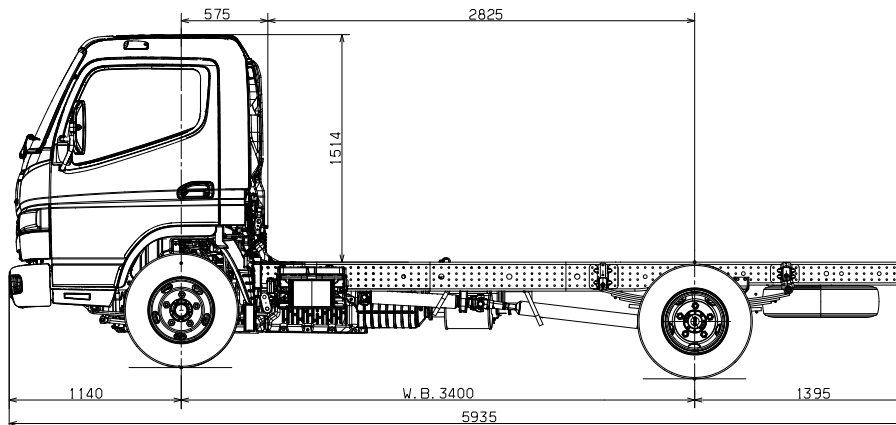

**CANTER 516 – 'E' WHEELBASE**

1000  
UNIT: mm 20mm = 1m

Scale = 1:50 (20mm = 1 metre). This scale is accurate when used on the original spec sheet, be aware that enlarging these illustrations can alter the scale and cause incorrect measurements. Fuso New Zealand and its authorised dealers always recommend customers seek professional advice from independent sources before commencing any engineering activities.

A policy of continual improvement means that specifications detailed in this brochure are subject to change without notice. Contact your authorised Fuso dealer to confirm current specifications. Fuso is a registered trademark of Mitsubishi Fuso Truck & Bus Corporation. Copyright © Fuso NZ (2017)