

CREW CAB

CANTER 816

DUONIC AMT OR MANUAL



GVM:
7,500kg



Power/Torque:
110kW/370Nm



Wheelbase:
3,400mm (E) / 3,850mm (G)

- 30,000km service intervals
- Seven seats
- Disc brakes
- Driver's suspension seat

SPECIFICATIONS - CANTER 816 CREW CAB

MODEL

4X2 816	WIDE CREW CAB	6 SP.	AMT	FEB71ER3WFAC
4X2 816	WIDE CREW CAB	6 SP.	AMT	FEB71GR3WFAC
4X2 816	WIDE CREW CAB	5 SP.	MAN	FEB71GR4WFAC

WHEELBASE

3,400mm (E)
3,850mm (G)
3,850mm (G)

GVM (optional)

7,500kg (5,995kg)
7,500kg (5,995kg)
7,500kg (5,995kg)

GCM (optional)

11,000kg (9,500kg)
11,000kg (9,500kg)
11,000kg (9,500kg)

ENGINE

Engine Version	FUSO 4P10-T4 Euro 5 Diesel
Configuration	4 Cyl. In-line DOHC, 4-Valve
Type	Variable Geometry Turbo Charged Air to Air Intercooled
Displacement	3 litre (2998cc)
Power (DIN)	110kW @ 2840~3500rpm
Torque (DIN)	370Nm @ 1350~2840rpm
Maximum Engine Speed (rpm)	4100
Compression Ratio	17.5:1
Cooling System/Oil Cooler	Water cooled with Viscous fan, 14.8L capacity. Engine oil cooler
Air Cleaner	Paper Element Type with Restrictor Indicator. Vertical Intake Mounted on Clean Air Side (RH)
Cold Start Preheat	Standard
Emission Control	Diesel Particulate Filter (DPF) Exhaust Dash Display DPF Status 0~9 (Empty~Full) Parked Regeneration possible from 7~9
Emission Level	EURO 5 (ADR 80/03) and EEV rated (Enhanced Environmentally-Friendly Vehicle)

4P10-T4

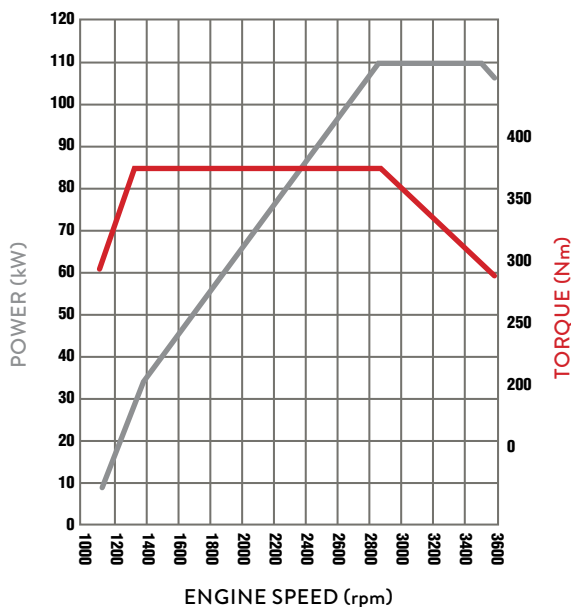

FUEL

Injection System	Bosch Common Rail Direct Injection Bosch Piezo Technology Injectors
Tank Type	Rectangular Steel Tank with Locking Cap
Fuel Capacity (L)	100
Filtration	Filter with Water Separator and Indicator Sensor

ELECTRICAL

Voltage	12V Negative Earth
Alternator Capacity	12V-110 amp
Battery Specification	Heavy Duty 115D31L x 2

ELECTRICAL

Headlamp Type	Halogen 2 x 55W/60W
Fog lamp in bumper	Standard

CLUTCH

	DUONIC AMT	Manual
Clutch Model	DUONIC Automated Manual (no clutch pedal)	FUSO C4W30
Type	Dual Clutch (Wet Multi-plate)	Single Dry Plate, Direct Hydraulic Type, 300mm

TRANSMISSION

	DUONIC AMT	Manual
Version	FUSO DUONIC M038S6	FUSO M038S5
Type/Speeds	6 Speed Automated Manual with Auto and Manual Modes	5 Speed with In-Dash Gearshift Lever
Features	Virtually Instant Gear Changes In-Dash Gear Lever with Park Brake Position ECO Mode to Minimise Fuel Usage	Synchromesh 2nd-5th
Ratios	1st: 5.397 2nd: 3.788 3rd: 2.310 4th: 1.474	5th: 1.000 6th: 0.701 Rev. 5.397
PTO Opening	LH Side	LH Side

FRONT AXLE

Axle Version	FUSO F350T "I" Beam
Design Capacity (kg)	3,100
Max Operating Capacity (kg)	3,100

FRONT SUSPENSION

Type	Taper leaf spring with Stabiliser Bar and Double Acting Shock Absorbers
Size (mm)	1,150 x 70

REAR AXLE

Axle	FUSO D035 Full Floating Banjo
Ratio	DUONIC 5.714:1 Manual 5.285:1
Design Capacity (kg)	6,000
Max Operating Capacity (kg)	6,000

REAR SUSPENSION

Type	Steel Suspension
Details	Multi Leaf Spring with Stabiliser Bar and Double Acting Shock Absorbers
Size Main Leaves (mm)	1,250 x 70
Size Helper Leaves (mm)	880 x 70

STEERING

Power Assisted	Tilt/Telescopic Adjustable Steering Wheel
----------------	---

SPECIFICATIONS - CANTER 816 CREW CAB

BRAKES (continued)

Type	Hydraulic Dual Circuit with Front and Rear Twin Calliper Disc Brakes
Size Front/Rear (mm)	310 x 40
Features	ABS plus EBD (Electronic Brake Distribution) Exhaust Brake Brake Priority System
Park Brake	Transmission Mounted

WHEELS AND TYRES

Wheel Type	7 x Single Piece Disc Rims (Including Spare)
Wheel Size	17.5 x 6.0-127
Wheel Stud Pattern	6 Stud 222.25 PCD
Tyre Size All	215/75R17.5 (Traction tyre on rear - FEB71ER3 and FEB71GR4)
Spare Tyre Carrier	Provided

CHASSIS

Type	Reinforced Tapered Channel
Size (mm)	192 x 60 x 6
Width (mm)	750
Refer to the bodybuilders guidelines on the Fuso website (www.fuso.co.nz) before mounting a body or modifying the chassis	

INSTRUMENTS

Gauges	Speedometer with Odometer, Tachometer Fuel Level, Water Temperature
Colour Information Display	Fuel Consumption, DPF Bar Chart from 1-9 Water Temperature, Maintenance Reminder System, Date and Time, Tripmeters x 2

STANDARD FEATURES

Airbag(s)	Dual Air Bags and Seat Belt Pre-Tensioners (Driver and Far Side Front Passenger)
Hill Start System	Adjustable Engagement on manual transmissions
Speed Limiter	Activated and adjustable by Fuso dealer
Cab Cooling and Heating	Air Conditioner / Heater / Demister
Accessory Power	12V Accessory Power Outlet / Cigar Lighter
Driving	AM/FM CD + USB + AUX + Bluetooth Hands Free Keyless Central Locking Electric Windows (front only) LED Map Lamp and Fluorescent Cabin Lamp Cup Holders (2)
Storage	Dual Overhead Storage Pockets In-Dash Centre Document Storage Door Storage Pockets Storage Under Rear Crew Seats Coat Hooks

STANDARD FEATURES (continued)

Cab: External	Front End-Outline Marker Lamps Front Step Lights
Chassis	Reverse Warning Buzzer

CAB FEATURES

Type	All Steel Forward Control Fixed Cab
Cab Structure	ECE-R29 European Cab Strength Approved with Front Door Side Impact Beams
Mounting	6 Point Isolated Rubber
Additional Engine Access	Removable Engine Access Panel
Colour	Natural White (W31)
Windscreen Wipers	2 Speed + Intermittent Cycle with Integrated Washer Nozzles
Rear Vision Mirrors	1 x Internal 2 x External Convex Heated
Interior	Fully Trimmed cab with Vinyl Floor Covering
Seating Capacity	7
Seat Belts	Driver - Height adjustable ELR 3 Point with tension reducer Outside Passengers - ELR 3 point Centre Passengers - Lap belt
Seat (driver)	Heavy Duty Suspended with LH Arm Rest, Adjustable Lumbar Support and Weight Adjustment. Cloth Trim
Seats (front passengers)	Flat Folding, 2 Passenger Bench with headrest in outside position
Seats (crew cab rear)	Low Back Bench Seat with headrests in outside position

SERVICE INTERVALS

Please contact your nearest Fuso dealer for details

WARRANTY

36 months or 100,000km (whichever occurs sooner)
Subject to terms and conditions in the Fuso Warranty Booklet

PERFORMANCE

	DUONIC AMT	Manual
Turning Circle (kerb to kerb - metres)	E = 12.2 G = 13.6	G = 13.6
Road Speed (km/h) at Max Engine Speed	127	130
Engine Speed (rpm) at 90km/hr (top gear)	2535	2420
Gradeability at Rated GVM (theoretical)*	29%	29%
Notes	*This is theoretical performance only. Actual performance may vary under different conditions	

KERB WEIGHTS AND MAX AXLE LOADS (kg)

Model		Vehicle Ratings**		Max Axle Loadings**		Kerb Weights*		
		GVM	GCM	Front	Rear	Front	Rear	Total
4x2 816 Wide Crew Cab 6 Sp. AMT	FEB71ER3WFAC	7,500	11,000	3,100	6,000	1,750	900	2,650
4x2 816 Wide Crew Cab 6 Sp. AMT	FEB71GR3WFAC	7,500	11,000	3,100	6,000	1,770	900	2,670
4x2 816 Wide Crew Cab 5 Sp. MAN	FEB71GR4WFAC	7,500	11,000	3,100	6,000	1,750	900	2,650
4x2 616 Wide Crew Cab 6 Sp. AMT	FEB71ER3WFAC(D)	5,995	9,500	3,100	6,000	1,750	900	2,650
4x2 616 Wide Crew Cab 6 Sp. AMT	FEB71GR3WFAC(D)	5,995	9,500	3,100	6,000	1,770	900	2,670
4x2 616 Wide Crew Cab 5 Sp. MAN	FEB71GR4WFAC(D)	5,995	9,500	3,100	6,000	1,750	900	2,650

* Weights (est.) includes 10L fuel & spare wheel and are subject to 2.5% variation (+/-)

** Vehicle ratings and max axle loadings may be limited by local regulations.

SPECIFICATIONS - CANTER 816 CREW CAB

DIMENSIONS (mm)

	E Wheelbase	G Wheelbase
Wheelbase	3,400	3,850
Length Overall	5,935	6,685
Height Overall	2,225	2,225
Width Overall	2,030	2,030
Width Rear Axle	2,030	2,030

	E Wheelbase	G Wheelbase
Width Front Track	1,675	1,675
Width Rear Track	1,560	1,560
Width Frame	750	750
Height Frame at Rear Axle	795	794

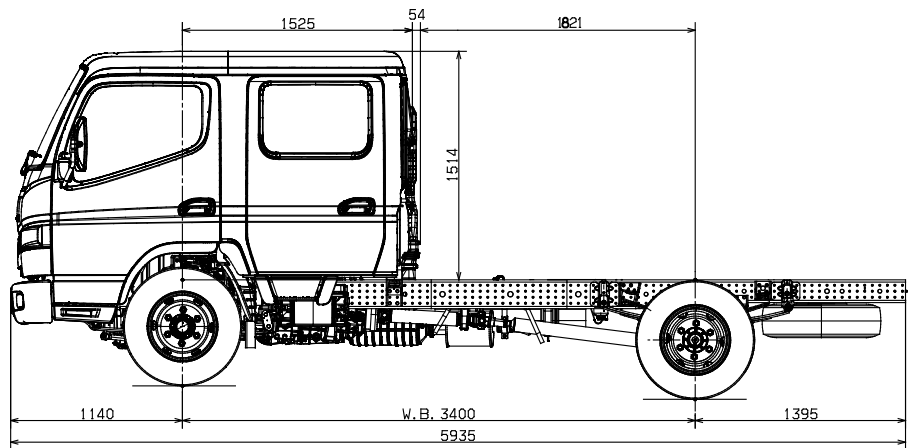

CANTER 816 CREW CAB – 'E' WHEELBASE

UNIT: mm 20mm=1m

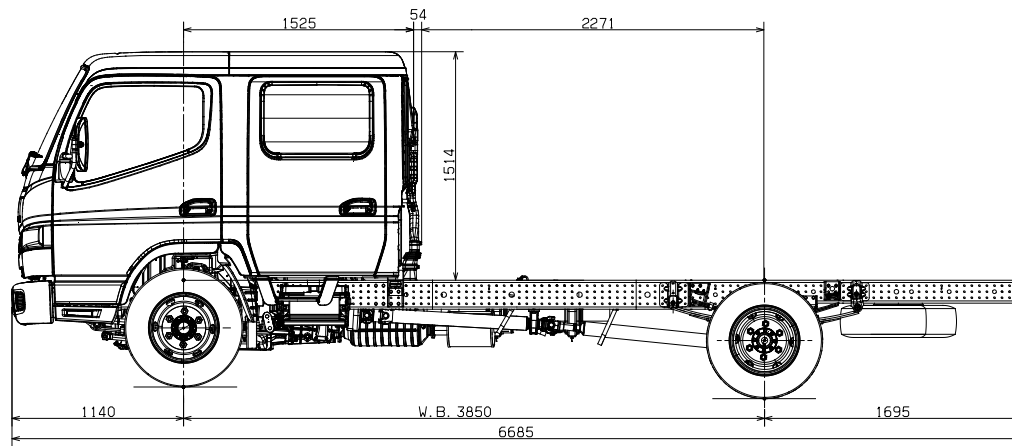

CANTER 816 CREW CAB – 'G' WHEELBASE

UNIT: mm 20mm=1m

Scale = 1:50 (20mm = 1 metre). This scale is accurate when used on the original spec sheet, be aware that enlarging these illustrations can alter the scale and cause incorrect measurements. Fuso New Zealand and its authorised dealers always recommend customers seek professional advice from independent sources before commencing any engineering activities.

A policy of continual improvement means that specifications detailed in this brochure are subject to change without notice. Contact your authorised Fuso dealer to confirm current specifications. Fuso is a registered trademark of Mitsubishi Fuso Truck & Bus Corporation. Copyright © Fuso NZ (2017)