

FIGHTER FK1228

4x2 • MANUAL



GVM:
12,000kg



Power / Torque:
207kW / 802Nm



Wheelbase:
5,210 mm (L) / 5,540mm (M)

- 30,000km service intervals
- High-power engine
- Isringhausen driver's seat
- Low-height chassis

SPECIFICATIONS - FIGHTER FK1228

MODEL

| | | | | |
|------------|-------|-----|-----------|-----------------|
| 4x2 FK1228 | 6 SP. | MAN | AIR SUSP. | FK65FLZ2RFAC(D) |
| 4x2 FK1228 | 6 SP. | MAN | AIR SUSP. | FK65FMZ2RFAC(D) |

WHEELBASE (mm)

| |
|-----------|
| 5,210 (L) |
| 5,540 (M) |

GVM (kg)

| |
|--------|
| 12,000 |
| 12,000 |

GCM (kg)

| |
|--------|
| 20,000 |
| 20,000 |

ENGINE

| | |
|----------------------------|--|
| Engine Version | FUSO 6M60-9AT2 Diesel |
| Configuration | 6 Cyl. In-line OHC, 4-Valve |
| Type | Variable Geometry Turbo Charged Air to Air Intercooler |
| Displacement | 7.5 litre (7545cc) |
| Power ECE Nett | 199kW @ 2500rpm |
| Torque ECE Nett | 785Nm @ 1100-2400rpm |
| Power (JIS Gross)* | 207kW (281ps) @ 2500rpm |
| Torque (JIS Gross)* | 802Nm(592lbft) @ 1100-2400rpm |
| Maximum Engine Speed (rpm) | 2900 |
| Compression Ratio | 16.0:1 |
| Cooling System/Oil Cooler | Water cooled, with Viscous fan, 23.0L capacity. Engine Oil Cooler |
| Air Cleaner | Paper Element Type with Restrictor Indicator. Vertical Intake Mounted on Clean Air Side (RH) |
| Cold Start Preheat | Standard |
| Emission Control | Selective Catalytic Reduction (SCR) After-Treatment System (BlueTec), Positive Crankcase Ventilation (PCV) |
| Emission Level | Euro 5 (ADR 80/03) |

*Calculated

6M60-9AT2

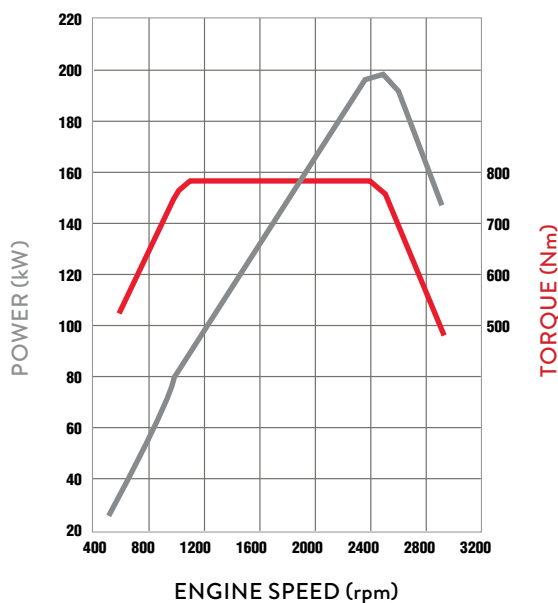

FUEL

| | |
|-----------------------------------|---|
| Injection System | DENSO Common Rail System Electronically Controlled Direct Injection |
| Tank Type | Rectangular Steel Tank with Locking Cap |
| Fuel Capacity (L) | 200 |
| AdBlue Exhaust Fluid Capacity (L) | 40 |

ELECTRICAL

| | |
|-----------------------|--------------------------------|
| Voltage | 24V Negative Earth |
| Alternator Capacity | 24V-80 amp |
| Battery Specification | Heavy Duty 2 x 12V, 100Ah/20hr |
| Headlamp Type | Halogen 2 x 70W/75W |

CLUTCH

| | |
|-------------------------|---------------------------------|
| Clutch Model | FUSO C7M38 |
| Type | Single Plate Cerametallic 380mm |
| Operation/Specification | Air Assisted Hydraulic |

TRANSMISSION

| | |
|-------------|--|
| Version | FUSO Manual M070S6-OD |
| Type/Speeds | 6 with Air Assisted Gearshift |
| Features | Synchromesh 2nd-6th |
| Ratios | 1st: 6.807 2nd: 4.172 3rd: 2.396 4th: 1.504 5th: 1.000 6th: 0.774 Rev. 6.807 |
| PTO Opening | LH Side |

PROPELLER SHAFT

| | |
|-----------------|---------------|
| Type | P10 |
| Universal Joint | Needle Roller |

FRONT AXLE

| | |
|-----------------------------|---------------------|
| Axle | FUSO F500T "I" Beam |
| Design Capacity (kg) | 5,000 |
| Max Operating Capacity (kg) | 5,000 |

FRONT SUSPENSION

| | |
|-----------|---|
| Type | Taper Leaf spring and Double Acting Shock Absorbers |
| Size (mm) | 1,300 x 70 |

REAR AXLE

| | |
|-----------------------------|---|
| Axle | FUSO D052 Full Floating Hypoid |
| Design Capacity (kg) | 9,500 |
| Max Operating Capacity (kg) | 9,200 |
| Ratio | L wheelbase 4.875:1 M wheelbase 4.625:1 |

REAR SUSPENSION

| | |
|--------------|--|
| Type | Air Suspension |
| Details | Trailing Arm With Air Dump Control and Double Acting Shock Absorbers |
| Air Spring | Air Spring - 2x270mm dia. per axle |
| Trailing Arm | 2 leaf |

STEERING

| | |
|----------------|---|
| Power Assisted | Tilt/Telescopic Adjustable Steering Wheel |
|----------------|---|

SPECIFICATIONS - FIGHTER FK1228

BRAKES

| | |
|------------------------|--|
| Type | Full Air, Dual Circuit, FUSO Taper Roller, Automatic Brake Adjustment, ABS |
| ASR (Traction Control) | Yes |
| Size Front/Rear (mm) | 370 x 150 |
| Park Brake | Rear Wheel Spring Actuated |
| Auxiliary | Exhaust Brake |
| Compressor | Water Cooled, 340cc Single Cyl. with air dryer |

WHEELS AND TYRES

| | |
|--------------------|-----------------------|
| Wheel Type | 7, Single Piece Disc |
| Wheel Size | 19.5 x 6.75DC-147-13t |
| Wheel Stud Pattern | 8 Stud 275mm PCD ISO |
| Tyre Size All | 265/70R19.5 |
| Spare Tyre Carrier | Provided |

CHASSIS

| | |
|------------|-------------------------------------|
| Type | Parallel Channel with Reinforcement |
| Size (mm) | 230 x 80 x 8.0 |
| Width (mm) | 844 |

Refer to the bodybuilders guidelines on the Fuso website (www.fuso.co.nz) before mounting a body or modifying the chassis

INSTRUMENTS

| | |
|----------------------------|--|
| Gauges | Speedometer with Odometer Tachometer Air Pressure (2) Fuel Level Water Temperature |
| Colour Information Display | Fuel Consumption Service Indicators Hour Meter and Tripmeter |

STANDARD FEATURES

| | |
|-------------------------|--|
| Airbag | Driver's Air Bag and Seat Belt Pre-tensioner |
| Hill Start System | Yes |
| Cab Cooling and Heating | Air Conditioner / Heater / Demister |
| Accessory Power | 24V Accessory Power Outlet / Cigar Lighter |
| Driving | Keyless Central Locking Electric Windows Cruise Control LH Transom Window AM/FM CD + USB + AUX + Bluetooth Hands Free Cup Holders (4) Rear Quarter Glass Fluorescent Cabin Lamp and Interior Reading Lamps Engine Idle Speed Control |
| Storage | Centre Seat Storage Console Rear Bunk Storage Pocket Dash Storage Tray 2 DIN Glove Compartment 1 Single and 1 Double DIN Slot for Accessories Overhead Storage Pocket with Lid RH Door Storage Pocket |

KERB WEIGHTS AND MAX AXLE LOADS (kg)

| Model | Vehicle Ratings** | Max Axle Loadings** | | Kerb Weights* | | | | |
|--------------------------------|-------------------|---------------------|--------|---------------|-------|-------|-------|-------|
| | | GVM | GCM | Front | Rear | Total | | |
| 4x2 FK1228 6 Sp. Man Air Susp. | FK65FLZ2RFAC(D) | 12,000 | 20,000 | 5,000 | 9,200 | 2,485 | 1,560 | 4,045 |
| 4x2 FK1228 6 Sp. Man Air Susp. | FK65FMZ2RFAC(D) | 12,000 | 20,000 | 5,000 | 9,200 | 2,495 | 1,570 | 4,065 |

* Weights (est.) includes 10L fuel and spare wheel and are subject to 2.5% variation (+/-)

** Vehicle ratings and max axle loadings may be limited by local regulations.

STANDARD FEATURES (continued)

| | |
|---------------|--|
| Cab: External | Roof Mounting Points (max. static load 70kg) Front End-Outline Marker Lamps |
| Chassis | Chassis Mounted Tool Box Reverse Warning Buzzer |

CAB FEATURES

| | |
|---------------------|---|
| Type | All Steel Forward Control Manual Tilt 44 deg. |
| Mounting | Hydroelastic Susp. 4 Point |
| Colour | Natural White (W31) |
| Interior | Fully Trimmed |
| Windscreen | Laminated Tinted |
| Windscreen Wipers | 2 Speed + Intermittent Cycle with Integrated Washer Nozzles |
| Door | 90 degree Opening Angle |
| Rear Vision Mirrors | Remote / Heated with Convex Spotter (Both Sides) |
| Seating Capacity | 3 |
| Seat Belts | 2 ELR Lap Sash, 1 Lap |
| Seat (driver) | ISRI Air Suspension with Auto Levelling, Height, Tilt and Dampening Adjustment Integral Headrest and Fabric Trim |
| Seats (passenger) | Centre: Low Back with Fabric Trim and Forward Folding LH Passenger: Fixed Base with Reclining Seat Back Integral Headrest and Fabric Trim |

PERFORMANCE

| | L Wheelbase | M Wheelbase |
|--|-------------|-------------|
| Turning Circle (kerb to kerb - metres) | 18.2 | 19.4 |
| Road Speed (km/h) at Max Engine Speed | 122 | 128 |
| Engine Speed (rpm) at 90km/hr (top gear) | 2130 | 2030 |
| Gradeability at Rated GVM (theoretical)* | 48% | 45% |
| Gradeability at Rated GCM (theoretical)* | 30% | 28% |

Notes *This is theoretical performance only. Actual performance may vary under different conditions

SERVICE INTERVALS

Please contact your nearest Fuso dealer for details

WARRANTY

36 months or 150,000km (whichever occurs sooner)
Subject to terms and conditions in the Fuso Warranty Booklet

SPECIFICATIONS - FIGHTER FK1228

DIMENSIONS (mm)

| | L Wheelbase | M Wheelbase |
|-----------------|-------------|-------------|
| Wheelbase | 5,210 | 5,540 |
| Length Overall | 8,645 | 9,075 |
| Height Overall | 2,530 | 2,530 |
| Width Overall | 2,270 | 2,270 |
| Width Rear Axle | 1,710 | 1,710 |

| | L Wheelbase | M Wheelbase |
|---------------------------|--------------|--------------|
| Width Front Track | 1,780 | 1,780 |
| Width Rear Track | 1,710 | 1,710 |
| Width Frame | 844 | 844 |
| Height Frame at Rear Axle | 858 Inflated | 858 Inflated |

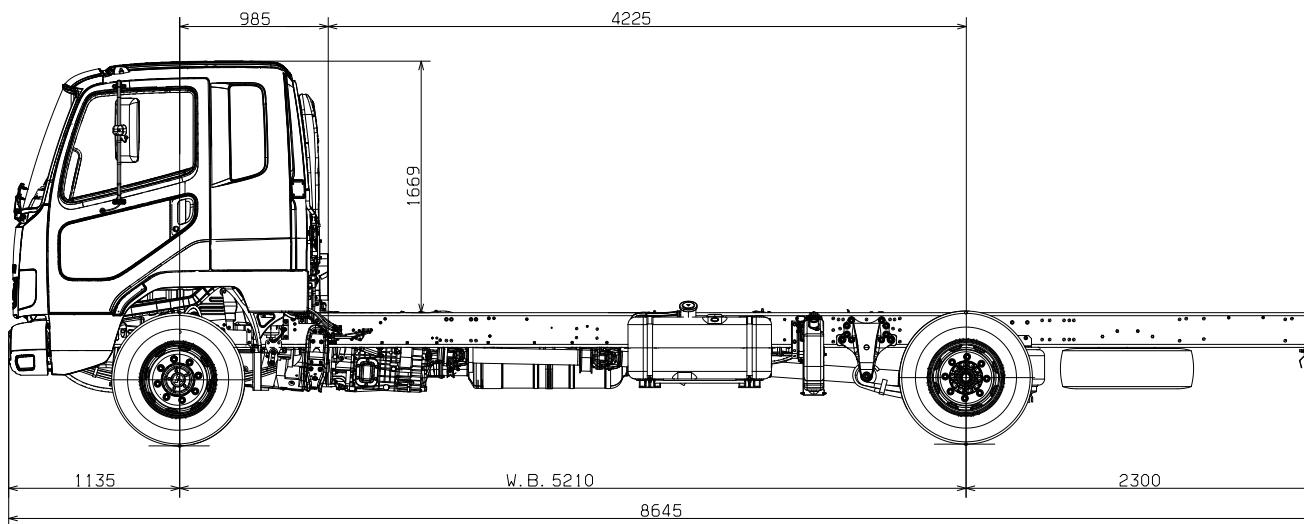

FIGHTER FK1228 – 'L' WHEELBASE

1000
UNIT: mm 20mm = 1m

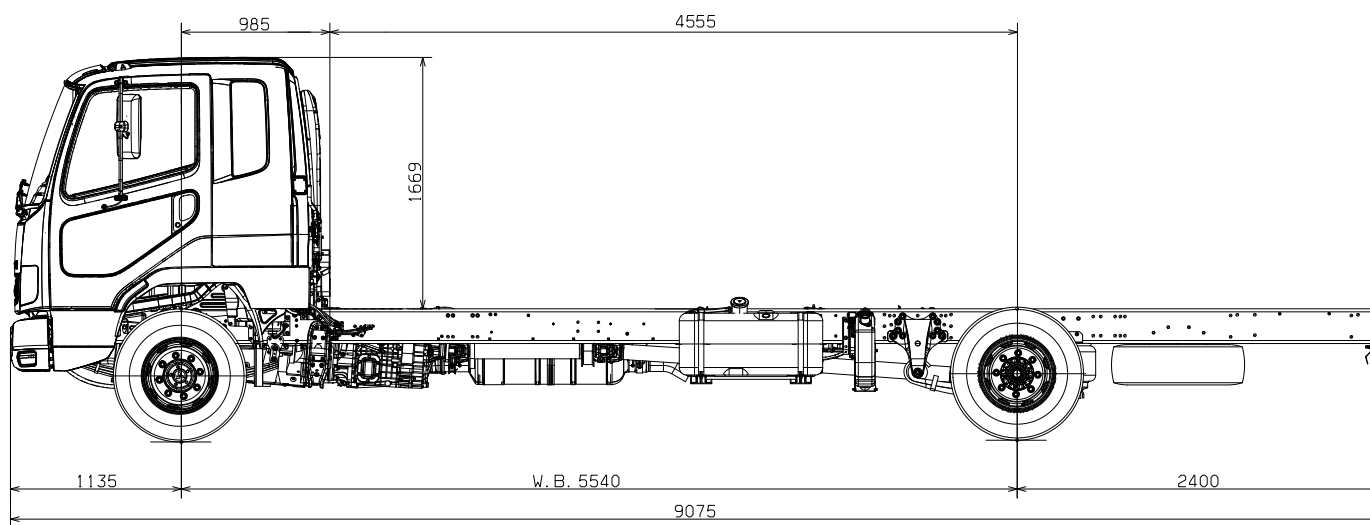

FIGHTER FK1228 – 'M' WHEELBASE

1000
UNIT: mm 20mm = 1m

Scale = 1:50 (20mm = 1 metre). This scale is accurate when used on the original spec sheet, be aware that enlarging these illustrations can alter the scale and cause incorrect measurements. Fuso New Zealand and its authorised dealers always recommend customers seek professional advice from independent sources before commencing any engineering activities.

A policy of continual improvement means that specifications detailed in this brochure are subject to change without notice. Contact your authorised Fuso dealer to confirm current specifications. Fuso is a registered trademark of Mitsubishi Fuso Truck & Bus Corporation. Copyright © Fuso NZ (2017)